

- Approval Condition: This Plan Sanction is issued subject to the following conditions: 1. The sanction is accorded for... 2. The sanction is accorded for Bungalow A (RESI) only... 3. Car Parking reserved in the plan should not be converted for any other purpose...

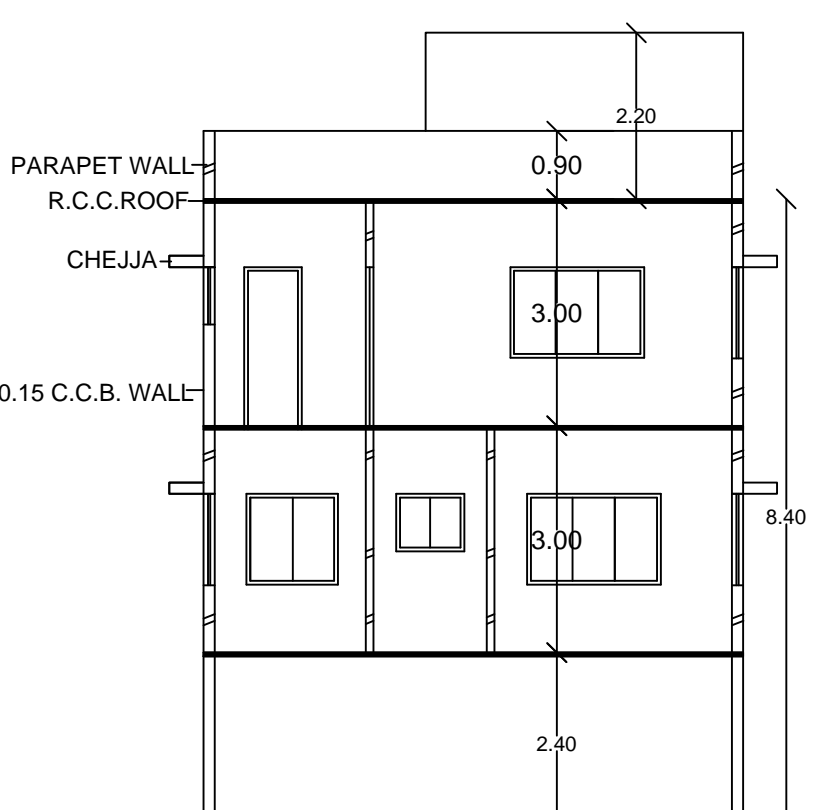
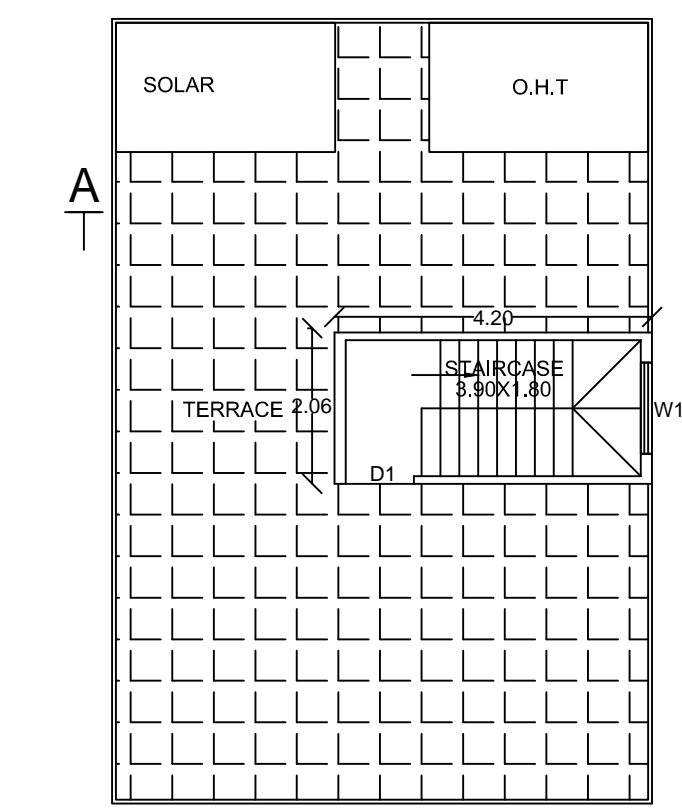

- 12. The applicant shall maintain during construction such barricading as considered necessary to prevent dust, debris & other materials endangering the safety of people / structures etc. in & around the site. 13. Permission shall be obtained from forest department for cutting trees before the commencement of the work. 14. License and approved plans shall be posted in a conspicuous place of the licensed premises...

- 31. Sufficient two wheeler parking shall be provided as per requirement. 32. Traffic Management Plan shall be obtained from Traffic Management Consultant for all high rise structures which shall be got approved from the Competent Authority if necessary. 33. The Owner / Association of high-rise building shall obtain clearance certificate from Karnataka Fire and Emergency Department every Two years with due inspection by the department regarding working condition of Fire Safety Measures installed...

Color Notes

COLOR INDEX

Table with 2 columns: COLOR INDEX and corresponding line styles for Plot Boundary, Abutting Road, Proposed Work, Existing, and Demolished.

AREA STATEMENT (BBMP) table with columns: AREA STATEMENT (BBMP), VERSION NO., VERSION DATE, PROJECT DETAIL, AREA OF PLOT, NET AREA OF PLOT, COVERAGE CHECK, FAR CHECK, and BUILT UP AREA CHECK.

Approval Date :

OWNER / GPA HOLDER'S SIGNATURE: OWNER'S ADDRESS WITH ID NUMBER & CONTACT NUMBER: Sri. N.CHIKKABYRAIAH. NO-248, SY.NO-1, J.B.KAVAL, NANDINI LAYOUT, WARD NO-43, BANGALORE. PID NO:12-150-248

ARCHITECT/ENGINEER /SUPERVISOR 'S SIGNATURE: K.S. Prasanna Kumar Sri Sai Enterprises/No. 3309, 1st Main Road, Opp More Retail Shop, Gayathri Nagar, BCC/BI/ 2/2/12/126/02/04

PROJECT TITLE : PLAN SHOWING THE PROPOSED RESIDENTIAL BUILDING AT SITE NO-248, SY. NO-1, J.B.KAVAL, NANDINI LAYOUT, WARD NO-43, BANGALORE, PID NO:12-150-248.

DRAWING TITLE : 1598359860-29-12-202104-22-02\$. \$N.CHIKKABYRAIAH

SHEET NO : 1

SANCTIONING AUTHORITY :

This approval of Building plan/ Modified plan is valid for two years from the date of issue of plan and building licence by the competent authority.

Table for Sanctioning Authority with columns: ASSISTANT / JUNIOR ENGINEER / TOWN PLANNER and ASSISTANT DIRECTOR.

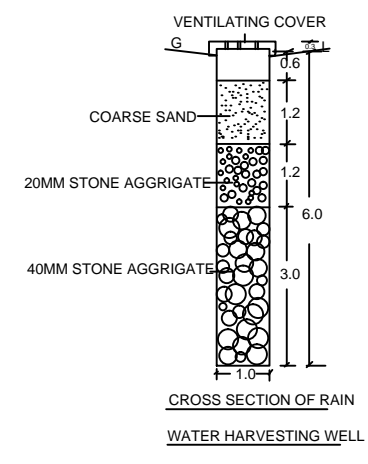

Block :A (RESI) table with columns: Floor Name, Total Built Up Area, Deductions, Proposed FAR Area, Total FAR Area, and Tnmt.

SCHEDULE OF JOINERY table with columns: BLOCK NAME, NAME, LENGTH, HEIGHT, NOS.

SCHEDULE OF JOINERY table with columns: BLOCK NAME, NAME, LENGTH, HEIGHT, NOS.

UnitBUA Table for Block :A (RESI) table with columns: FLOOR, Name, UnitBUA Type, UnitBUA Area, Carpet Area, No. of Rooms, No. of Tenement.

FAR & Tenement Details table with columns: Block, No. of Same Bldg, Total Built Up Area, Deductions, Proposed FAR Area, Total FAR Area, Tnmt.

Parking Check (Table 7b) table with columns: Vehicle Type, Req'd, Achieved.

Block USE/SUBUSE Details table with columns: Block Name, Block Use, Block SubUse, Block Structure, Block Land Use Category.

Required Parking (Table 7a) table with columns: Block Name, Type, SubUse, Area, Units, Car.

